



Drive Source International, Inc.

7900 Durand Avenue, P.O. Box 0361
 Sturtevant, Wisconsin, U.S.A. 53177
 Tel: 262.554.7977 Fax: 262.554.7041
 Toll Free: 1.800.548.2169
 E-mail: sales@drivesourceusa.com
 Website: www.drivesourceusa.com

CHAIN CONVEYORS

Overhead Chain

Chain-type overhead and floor conveyors are used extensively in assembly operations in automotive plants. Many conveyors require adjustable speed because of:

1. General control of production rates.
2. Acceleration and deceleration control.
3. Product transfer from one conveyor to another.
4. Control of specific product operations such as painting, dipping, drying etc.

Conveyor Path Can Include Turns And Dips Where Needed. Overhead Track Supported From Floor Or Ceiling. Drives Are Sprocket Or Caterpillar Type. Multiple Drive For Long Runs.

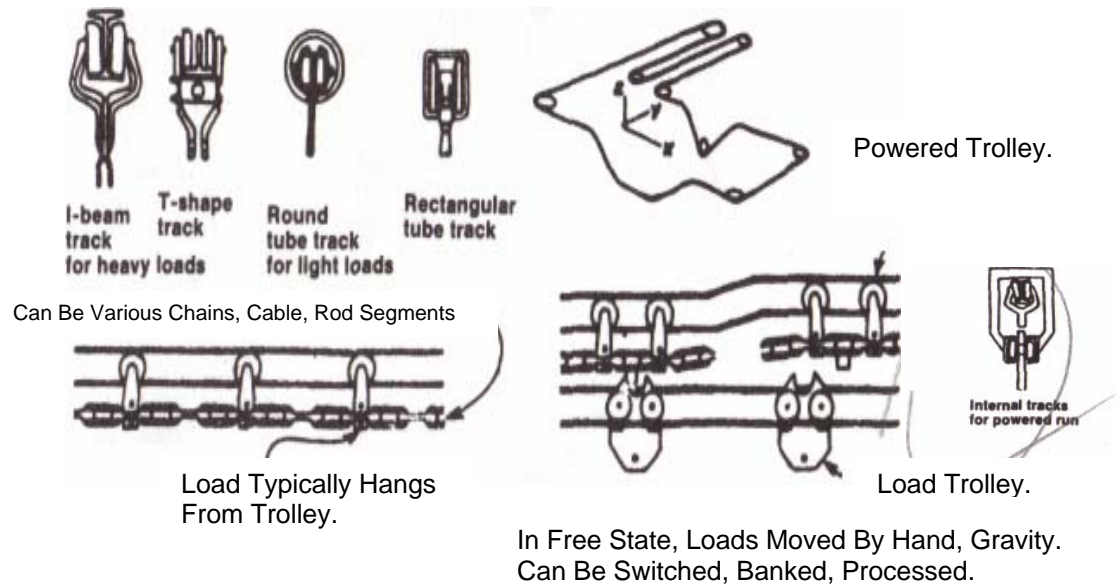

The overhead chain trolley conveyor consists of a series of trolleys supported from or within an overhead track and connected by an endless propelling medium with loads usually suspended from the trolley. In the power and free form, load-carrying free trolleys can move in and out of contact with pushers attached to powered trolleys.

Floor Assembly

A floor flat-top chain conveyor is an endless chain consisting of links with special top sections that create an articulated by essentially continuous, flat surface for handling objects placed on it.

Chain Below Floor

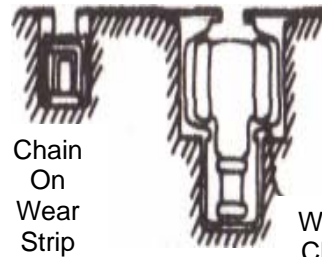

Trolley Supported Chain

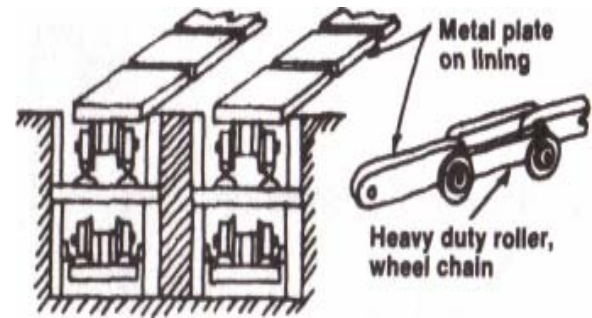

Rugged Version Of Flat Top Chain Handles Loads In Tons (coils, rolls) Note: Load Carried By Wheels On Rails

Single Chain

This drive type is Eddy-Current, up to 10 hp, with basic speed control on single drive conveyors. Where the conveyor is extremely long, multiple drives are used and distributed around the chain path. Clutch coils are connected in parallel or master/slave controls are used (Figure 17) to provide equal drive torques.

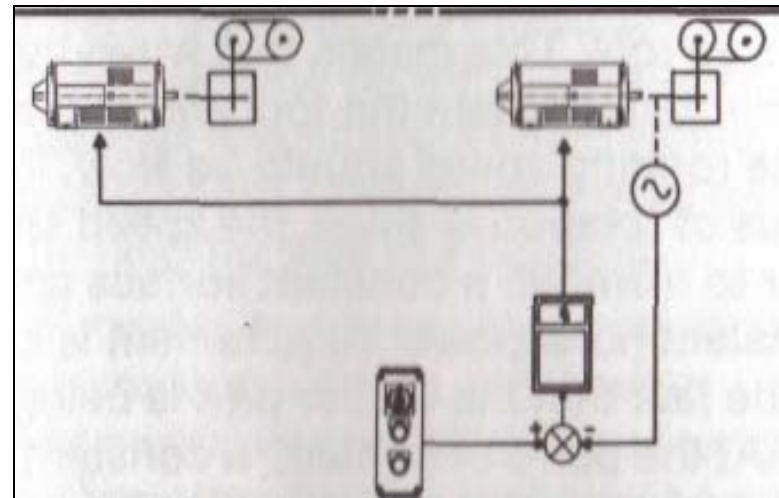

Multi-Conveyor

On multi-conveyor systems where there is storage capacity at the transfer points, the conveyor controls can be cascaded. Where the item being carried must be transferred from one conveyor to another at specific links on the second conveyor, the conveyors must be position synchronized.

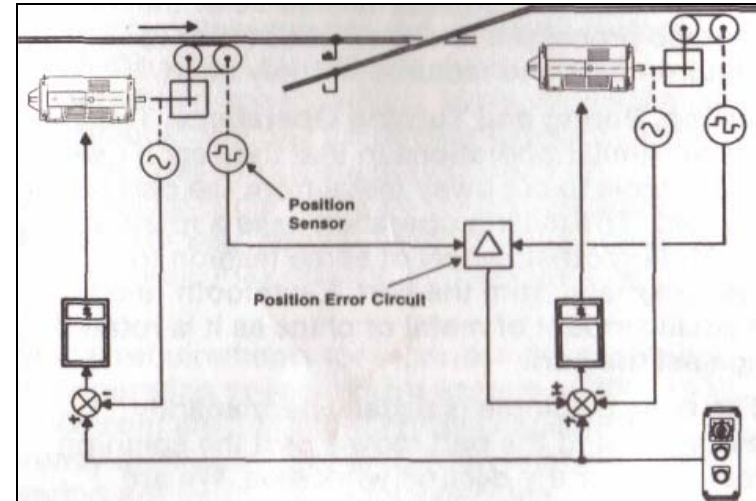

The Dynamic® name has been associated with various conveyor applications for many years. Some of our clientele include:

- The Ford Motor Company
- General Motors
- Fiat
- Butcher Engineering
- Mayfran Corporation

For further information or details on these and more conveyor applications, please contact one of our application specialists.

Application Engineering • Quality Products • Total Solution