

Specialty Products

CES PACKAGE PRESS DRIVES MODELS 37-21 TO 49-63



**16,600 to 89,000 lb. ft. Torque Capacity
High Capacity CES Press Drive**

The CES (Constant Energy System) Package Press Drive is a combination of an air-cooled adjustable speed drive, brake and belt ring flywheel in a common housing. The package is mounted in pedestals and tie bars on a base plate. Tubing is provided for supplying oil to the bearings. The press drive can function within a wide stroking range while exercising full control of the slide within individual strokes; and it can produce

sufficient inertia for normal single, double and triple action press applications. Optional air-operated shoe brakes (two required per drive) can be mounted against the outer diameter of the flywheel for faster braking capability. The CES features can be fully utilized by the following types of presses: blanking, deep draw, transfer, progressive die, follower, synchronized and multiple action.

Features	Customer Benefits
Microprocessor based control.	Ensures maximum operation flexibility and reliability.
Precise speed control while maintaining fixed flywheel speed; up to a 5:1 controllable speed range.	Ensures maximum production with minimum scrap.
Press logic safety circuits included.	Protects the operator and machinery from fault conditions.
Initial higher stroking rate of the slide can be resumed quickly after each cycle.	Provides a consistent, high production rate of finished customer products.
Electromagnetic adjustable speed clutch design.	Reduces shock on press drive train.
Bearing oil sumps can be assembled in either of four positions.	Easy to install on different kinds of presses.
Low speed control, without adding additional cooling.	Eliminates the need for die setup motor.
Intra stroke speed changing capability.	Permits deep drawing without producing scrap and using excessive die lubricant.

Specialty Products

CES PACKAGE PRESS DRIVES MODELS 37-21 TO 49-63
Press Drive and Flexible Coupling Data

Press Drive Data				
Press Drive Model	Approximate Peak Torque Lb. Ft.		HP Per 100 RPM	Shaft Diameter
	Coupling	Brake		
37-21	16,600	8,300	343	6.25
37-32	25,500	16,500	525	6.25
37-42	34,500	16,500	725	6.88
49-42	65,000	32,000	-	7.62
49-63	95,000	47,500	-	9.00

Flexible Coupling Data					
Vendor	Size	Dimensions			
		A	B	C	D
Amerigear Faulk	105	16.56	12.50	13.56	15.25
	55G10	16.75	12.50	13.56	16.82
Amerigear Faulk	105	16.56	12.50	13.56	15.25
	55G10	16.75	12.50	13.56	16.82
Amerigear Faulk	106	18.00	13.50	15.12	16.50
	66G20	18.00	13.75	15.06	18.32
Amerigear Faulk	107	20.75	15.75	17.75	19.25
	70G20	20.75	16.00	17.75	21.38
Amerigear Faulk	109	Consult Factory			
	90G20				

Outline Drawings – 37 & 49 Series

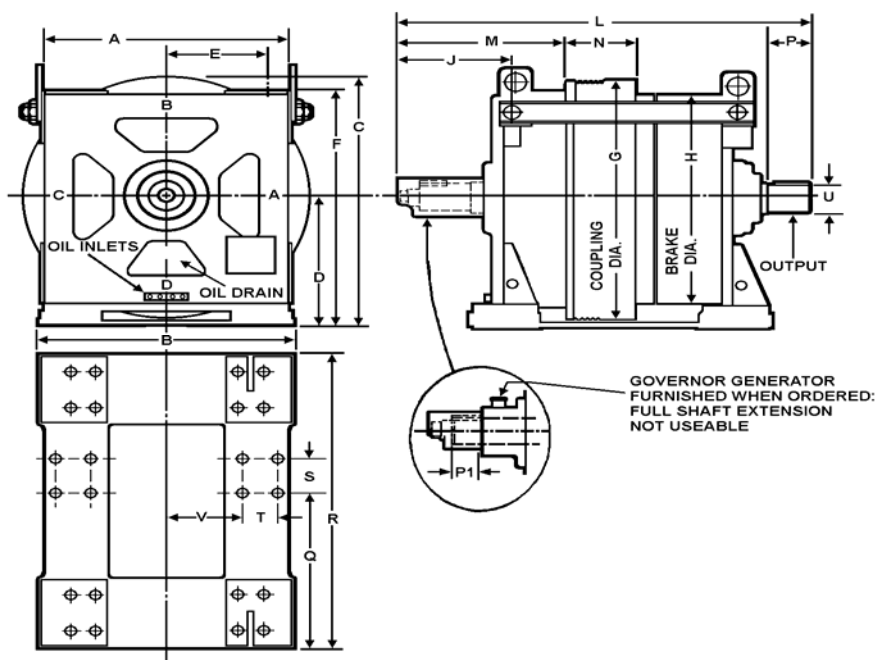

Dimensions – Inches (Approximate)

Model No.	A	B	C	D	E	F	G	H	J	L	M	N	P	P1	Q	R	S	T	U	V
37-21									18.05	77.40	29.18	13.38	8.75	-	34.13	60.12			6.250	
37-32	49	49.44	58.00	30	20	54.50	56	49	22.88	88.00	33.88	19.25	8.75	4.75	26.37	66.00	7.50	6.12	6.250	16.14
37-42									18.05	90.67	29.18	25.12	10.25	-	45.87	71.87			6.875	
49-42	57	56.92	69.00	36	24	64.50	66	60	25.88	104.50	38.25	25.12	12.00	7.00	45.80	77.68	10.50	8.50	7.625	17.50
49-63			73.00	38		66.50	70		19.68	118.88	31.18	36.88	13.50	-	61.04	97.44	12.50	9.50	9.000	15.46

7900 Durand Avenue
 PO Box 0361
 Sturtevant, WI 53177

Ph: 800-548-2169
 Ph: 262-554-7977
 Fax: 262-554-7977

Email: sales@drivesourceusa.com
 Website: www.drivesourceusa.com