

**"AS" Ajusto-Spede® Drives
1 through 30 HP**

**MODELS AS-14 THROUGH AS-27
Ordering Information**



Description:

Ajusto-Spede® Drives are a combination of an air-cooled, adjustable speed clutch and an integrally mounted NEMA B, AC induction motor. The Ajusto-Spede® Drive transmits constant torque at variable speeds. There is no physical contact between input and output members. This results in smooth response, thereby eliminating shock loading and extending equipment life. All drives have a C-Face endbell on both ends, TEFC Construction and an

internal tachometer generator mounted around the output shaft to provide a feedback signal to the drive's controller. The controller provides the DC excitation for the clutch coil. The feedback signal from the tachometer generator is compared to a reference signal within the controller to maintain accurate speed regulation. The controllers for the drives are described in the Product Catalog.

Features	Customer Benefits
AC power input - Ajusto-Spede® drives and controllers are available to run on virtually any three phase voltage input.	Compatible with existing wiring and plant power.
Approximately 250% motor torque available at clutch output.	Accelerates high inertia loads quickly and handles intermittent overloads without having to increase the horsepower rating.
Three-year warranty on Ajusto-Spede® mechanical drives.	Ajusto-Spede® Drives are built to give long, reliable, low cost life in diverse applications.
Simple design - drive consists of a clutch, AC induction motor and a separate controller.	Easy to understand, install, operate and maintain.
Fewer wearing parts - all Ajusto-Spede® Drives have only four bearings and no slip rings or brushes.	Minimum downtime and maximum production from initial start-up.
0.5% speed regulation is standard.	Provides a consistent, high quality customer product under changing load and environmental conditions.
Uses existing wiring and motor starters.	Easy to retrofit in industrial environments.
Controller circuits are transformer isolated from power lines.	Electronic controller is immune to line noise.
Stationary clutch coil design is standard.	Suitable for harsh industrial environments.
Controller operates on less than 2% of input power.	No need for costly, full power conversion units.

**"AS" Ajusto-Spede® Drives
1 through 30 HP**

Specifications for AS-14 Through AS-27 Drives

Motor	HP and RPM Totally Enclosed Fan Cooled NEMA design B Class F insulation, class B rise 1.15 service factor Frame type Input power Three-year warranty	See selection table Standard; ODP - Optional Standard Standard Standard Common housing - Standard 230/460V, 3 phase, 60 Hz - Standard Standard
Clutch	Coil voltages Rated for constant torque Starting torque Intermittent torque AC tachometer generator Cooling Three-year warranty	45 VDC - Standard; 90, 110, 220 VDC - Optional Standard Approximately 250% Approximately 250% Standard 100% self ventilated at all times -Standard Standard
Controllers (Sold Separately)	Model 3000 and Model 4000 (Solid State) Model 4050, DSI-600 and Mark III (Solid State) EC-2000 and PDC-2000 (Digital) Closed loop speed control Speed regulation Regulated speed range Input power Enclosure Panel mount, open construction Output voltage, to clutch coil One-year warranty	Can be used with AS-14 through AS-25 Can be used with AS-14 through AS-27 Can be used with AS-14 through AS-27 Standard 0.5% standard; 0.1% optional (EC-2000 only) 34 to 1 available 115 VAC Motor transformer winding (Standard Models only) – Standard; Line transformer - Optional NEMA 1 - Standard; NEMA 12 - Optional; NEMA 13 for 4000 & 4050 - Standard Optional 45 VDC or 90 VDC standard; 220 VDC optional (EC-2000 only) Standard
Status Indication	Speed indicating signal	0-60 VAC from tachometer generator for optional meter.
Environmental Ratings	Storage temperature Operating temperature Maximum operating temperature Altitude	-20° to 65° C (-4° to 149° F) Standard 0° to 40° C (32° to 104° F) Standard 65° C - Optional 1000m (3300 Ft.) Standard
Codes and Standards	Mechanical NEMA, as applicable Mechanical CSA Controllers CSA	Standard Approved Approved
Reliability Testing	Mechanical 100% dynamometer tested Controllers Pre-tested components Computer test and pre-calibrated PCBs	Standard Standard Standard

"AS" Ajusto-Spede® Drives

Product Information

The Ajusto-Spede® Model AS Drive includes an 1800 RPM AC motor, with 230 through 460 VAC, 3 phase, 60 Hz., 208/220 through 380 VAC, 3 phase, 50 Hz. or 575 VAC, 3 phase, 60 Hz., TEFC, 1.15 SF, NEMA design B, Class F insulation, integrally mounted to a brushless clutch in a common housing with 100% rated motor torque continuously available over the speed range shown. The service factor for drives specified with a 50 Hz. motor is 1.0. If an open drip-proof, 50 Hz. motor is specified, the service factor remains 1.15.

A controller is required, but not included. A Drive/Controller Compatibility and Selection Chart can be found starting on Page 70. Controllers can be found starting on Page 72. Operator stations can be found starting on Page 117. An internal 115 VAC center tapped transformer winding is included in the motor for controller power on standard units only. Standard units consist of the following: 45 or 90 VDC epoxy clutch coil, a second (loose) nameplate and 230 through 460 VAC, 3 phase, 60 Hz., 208/220 through 380 VAC, 3 phase, 50 Hz. or 575 VAC, 3 phase, 60 Hz. TEFC motor. A spherical roller bearing is included as standard on model AS-27 units only. ****Consult factory for non-standard units.**

Selection Table – 60 Hz, 45V Coil

HP	Speed Range (RPM)	Model Number
1	1730-0	AS-140104-0145
	1095-0	AS-140106-0145
1.5	1695-0	AS-140154-0145
	1130-0	AS-180156-0145
2	1640-0	AS-140204-0145
	1120-0	AS-180206-0145
3	1710-570	AS-140304-0145
	1710-0	AS-180304-0145
	1105-0	AS-180306-0145
5	1670-0	AS-180504-0145
	1115-0	AS-210506-0145
7.5	1670-0	AS-210754-0145
	1140-0	AS-250756-0145
10	1650-175	AS-211004-0145
	1120-0	AS-251006-0145
15	1660-0	AS-251504-0145
	1110-0	AS-271506-0145
20	1660-440	AS-252004-0145
	1710-0	AS-272004-0145
	1080-100	AS-272006-0145
25	1690-0	AS-272504-0145
	1090-320	AS-272506-0145
30	1665-150	AS-273004-0145
40	1665-560	AS-274004-0145

Selection Table – 60Hz, 90V Coil

HP	Speed Range (RPM)	Model Number
1	1730-0	AS-140104-0190
	1095-0	AS-140106-0190
1.5	1695-0	AS-140154-0190
	1130-0	AS-180156-0190
2	1640-0	AS-140204-0190
	1120-0	AS-180206-0190
3	1710-570	AS-140304-0190
	1710-0	AS-180304-0190
	1105-0	AS-180306-0190
5	1670-0	AS-180504-0190
	1115-0	AS-210506-0190
7.5	1670-0	AS-210754-0190
	1140-0	AS-250756-0190
10	1650-175	AS-211004-0190
	1120-0	AS-251006-0190
15	1660-0	AS-251504-0190
	1110-0	AS-271506-0190
20	1660-440	AS-252004-0190
	1710-0	AS-272004-0190
	1080-100	AS-272006-0190
25	1690-0	AS-272504-0190
	1090-320	AS-272506-0190
30	1665-150	AS-273004-0190
40	1665-560	AS-274004-0190

**Catalog Numbering System Shown at Right:

**Consult factory for any additional accessories and/or modifications you may require that are not listed on the next page.

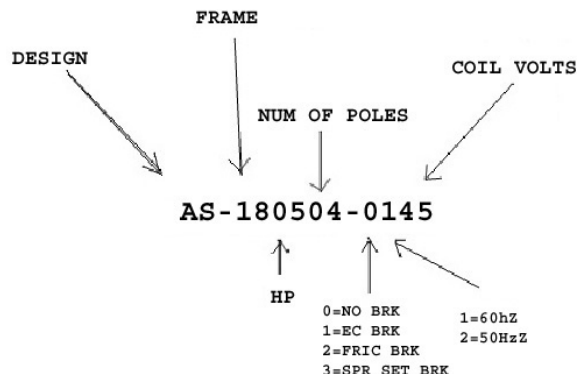

"AS" Ajusto-Spede® Drives

Modifications

Please consult factory for pricing on the following modifications:

Base, Slide - Adjustable slide bases are available for the horizontal mounting of an AS drive.

Part Number - AS-14 - 80907-0100
Part Number - AS-18 - 80907-0200
Part Number - AS-21 - 80907-0300
Part Number - AS-25 - 80907-0400
Part Number - AS-27 - 80907-0500

Brake, Adjustable Torque - An adjustable torque brake is flange mounted to the drive for stopping purposes or for use with the Mutuatrol® controller modification. Brakes require a brake circuit in the controller. Factory mounted on motor end standard.

Part Number - AS-14 - 81278-1045 (45V)/1090 (90V)
Part Number - AS-18 - 82278-1045 (45V)/1090 (90V)
Part Number - AS-21 - 83278-1045 (45V)/1090 (90V)
Part Number - AS-25 - 84278-1045 (45V)/1090 (90V)
Part Number - AS-27 - 91225-1045 (45V)/1090 (90V)

Brake, Friction - An electromagnetic friction brake is flange mounted to the drive for stopping or holding purposes. Brakes require a brake circuit in the controller. Factory mounted on motor end standard.

Part Number - AS-14 - 81130-1100 (45V)/1200 (90V)
Part Number - AS-18 - 82163-1100 (45V)/1200 (90V)
Part Number - AS-21 - 83130-1100 (45V)/1200 (90V)
Part Number - AS-25 - 84130-1100 (45V)/1200 (90V)
Part Number - AS-27 - 91143-1100 (45V)/1200 (90V)

Brake, Friction, with Thru Shaft - For cases where the motor end is already being used, the friction brake is mounted on the clutch end with a "thru" shaft arrangement (NOTE: "thru" shaft arrangement is factory installed only).

Part number - AS-14 - 81367-0100 (45V)
Part number - AS-18 - 82367-0100 (45V)/0200 (90V)
Part number - AS-21 - 83367-0100 (45V)/0200 (90V)
Part number - AS-25 - 84367-0100 (45V)/0200 (90V)
Part number - AS-27 - 91151-0100 (45V)/0200 (90V)

Brake, Spring-Set - A spring engaged, electrically released friction brake is flange mounted to the drive. These brakes are suitable for holding purposes. Brakes require a brake circuit in the controller (not for use with the model 3000 controller). The standard voltage supplied will be 115 VAC; other voltages are available by consulting the factory; with other voltages, the customer must supply relay and interfacing. Factory mounted on motor end standard.

Part Number - AS-14 - 81081-1100 (115V)/1200(230V)
Part Number - AS-18 - 82081-1100 (115V)/1200(230V)
Part Number - AS-21 - 83081-1100 (115V)/1200(230V)
Part Number - AS-25 - 84081-1100 (115V)/1200(230V)
Part Number - AS-27 - 91170-1100 (115V)/1200(230V)

Cover, Vertical Drip - A kit will be installed or provided with a sheet metal drip cover to prevent water from falling into the unit. Available as a ship loose item only.

Part Number - AS-14 - 81282-0100
Part Number - AS-18 - 82282-0100
Part Number - AS-21 - 85656-0100
Part Number - AS-25 - 85656-0200
Part Number - AS-27 - 91187-0100

Protection, Food Plant - Includes a TEFC motor, encapsulated tachometer and clutch coil, external epoxy paint, and nickel-plated endbells for chemical washdown duty. Class H insulation may be required for higher ambient. (Constant torque speed range will be reduced at ambient above 104° F).

Protection, Jungle - Includes a TEFC Motor, encapsulated clutch coil, screens over all air openings, and discharge louvers in the "up" position and external epoxy paint.

"AS" Ajusto-Spede® Drives

Modifications

Protection No.1 - Includes a TEFC motor, epoxy encapsulated tachometer and clutch coil. Class H insulation may also be required for higher ambient. (Constant torque speed range will be reduced at ambient above 104° F).

Protection, Paper Mill - includes all of the features of Protection No. 1 plus external epoxy paint. Class H insulation may also be required for higher ambient. (Constant torque speed range will be reduced at ambient above 104°F).

Protection, Screens Only - Includes screens over all drive air openings. This modification provides protection from entry of rodents, stones, etc.

Protection, Tropical - Includes all features of Protection No. 1 plus, screens over all air openings and the spraying of all practical surfaces with a special fungus retarding varnish. This modification provides drive protection for jungle environments.

Switch, Clutch Thermal - To safeguard the clutch drum from excessive heat a thermal switch is placed in the air stream. This switch has a NC contact.

"AS" Ajusto-Spede® Drives

Drive Engineering Data

Adjustable Speed Drive Data

Model	Clutch Torque Lb. Ft. at Slip RPM of ❶					Rated Dissipation HP at Input RPM of ❷					Inertia Lb. Ft. ² Output Member
	50	75	100	150	1750	900	1000	1200	1500	1800	
AS-14	4.0	5.5	7.0	9.0	25.0	1.0	1.0	1.1	1.6	2.0	.86
AS-18	10.0	14.0	16.0	21.0	46.0	2.5	2.6	3.1	4.1	5.0	1.96
AS-21	19.0	25.0	32.0	40.0	74.0	4.5	4.8	5.8	7.5	9.0	3.59
AS-25	42.0	56.0	68.0	82.0	120.0	7.5	8.0	9.6	12.4	15.0	6.22
AS-27❹	60.0	81.0	102.0	132.0	245.0	13.7	15.2	18.3	22.8	27.4	16.00
AS-27❺❻	75.0	102.0	124.0	155.0	250.0	13.7	15.2	18.3	22.8	27.4	16.00

Adjustable Speed Drive Data

Model	Overhung Load Lbs. at Output RPM of ❸			45V Clutch Coil Current (Hot Amps)	Weight Lbs.
	900	1200	1800		
AS-14	390	390	380	3.40	157
AS-18	600	550	470	3.90	277
AS-21	725	675	560	3.88	412
AS-25	1125	1020	880	4.18	610
AS-27❹	1510	1350	1155	7.20	1080
AS-27❺❻	1465	980	805	7.20	1090

- ❶ Values are for four-pole motor speeds
- ❷ Indicates maximum HP that can be safely dissipated at a given input speed. Dissipation should be de-rated 10% for each 10° F above 100° F ambient, to 150° F maximum ambient.
- ❸ Values are based on B-10 bearing life of 15,000 hours. For 20,000 hours use 91% of the values shown. The figures are the maximum weights at the center of a standard output shaft keyway perpendicular to the axis. Ratings are for ball bearings unless otherwise noted.
- ❹ AS-27 with 1.875" shaft diameter.
- ❺ Unit with copper plated clutch drum.
- ❻ AS-27 with 2.125" shaft diameter.

"AS" Ajusto-Spede® Drives

Brake Engineering Data

Adjustable Torque (Eddy Current) Brake Data

Model	Brake Torque in Lb. Ft. at Output RPM of			Brake Dissipation HP at Brake RPM of					Brake Inertia Lb. Ft.	Brake Coil 45V Current (Hot Amps)	*Approx. Weight
	900	1200	1800	300	600	900	1200	1800			
AS-14B	5.4	6.0	6.6	.15	.3	.5	.7	1.0	.13	1.84	177
AS-18B	26.0	28.0	30.0	.50	1.0	1.5	2.0	3.0	.60	2.49	322
AS-21B	30.0	32.0	34.0	.50	1.0	1.5	2.0	3.0	.60	2.49	457
AS-25B	40.0	60.0	60.0	.80	1.7	2.5	3.3	5.0	1.96	3.47	690
AS-27B	65.0	70.0	100.0	1.90	3.2	3.7	4.9	7.3	1.75	3.51	1180

Friction Brake Data

Model	Electrically Engaged			*Approx. Weight
	Static Torque Lb. Ft.	Inertia Lb. Ft.	Brake Model	
AS-14F	40	.054	500	177
AS-18F	40	.054	500	322
AS-21F	80	.371	825	457
AS-25F	80	.371	825	690
AS-27F	240	.967	310	1180

Spring Set Brake Data

Model	Spring Set Electrically Released Static Torque Lb. Ft.	*Approx. Weight
AS-14F	15	177
AS-18F	25	322
AS-21F	35	457
AS-25F	70	690
AS-27F	175	1180

Adjustable Torque & Friction Brake Data

Model	Overhung Load in Lbs. At Output RPM of 1800 Std.	*Approx. Weight
AS-14F	235	197
AS-18F	310	367
AS-21F	550	502
AS-25F	565	770
AS-27F	700	1280

*Approximate weight includes the weight of the drive.

"AS" Ajusto-Spede® Drives

Engineering Data

Induction Type, 3 Phase AC Motors, 4 Pole, Squirrel Cage Nema Design B

The full load motor currents shown in the table below are typical values for AS-14 through AS-27, 4 pole drives. This table is intended for use as an aid in sizing motor branch circuit components.

For full load motor currents of 200 and 208-volt motors, increase the corresponding 230 volt motor full load current by 15% and 10% respectively.

Full Load Currents

HP	Full Load Amperes		
	230 Volt	460 Volt	575 Volt
1	5.4	2.7	2.2
1.5	6.0	3.0	2.5
2	7.0	3.5	2.8
3	9.4	4.7	3.8
5	14.6	7.3	5.8
7.5	20.4	10.2	8.2
10	28.4	14.2	11.7
15	41.0	20.5	16.4
20	55.0	27.5	22.0
25	68.0	34.0	27.2
30	74.0	37.0	29.6

Noise Levels, Ajusto-Spede Drives Model AS Drives

These sound pressure levels are **typical** values given for engineering information only, and it is **not guaranteed** that any particular production unit will not exceed these values. Microphone 3 feet from side of drive, tested in a semi-anechoic chamber above reflecting plane per IEEE-85 spec. All readings are sound pressure level, dB; reference 20 micro Newton's per square meter. Average sound pressure in a 3-foot radius hemispherical free field. Noise level for 1200 RPM drives will be 8 dB less than 1800-RPM values shown, and for 3600 RPM the noise level will be 15 dB greater.

Noise Levels

Model	Sound Pressure dB			
	RPM	A Scale	B Scale	C Scale
AS-14	1800	66.3	-	70.0
AS-18	1800	70.2	-	74.5
AS-21	1800	75.3	-	79.1
AS-25	1800	80.5	-	83.9
AS-27	1800	82.0	-	85.1

"AS" Ajusto-Spede® Drives

Outline Drawings "C" Flange - AS-14 through AS-25

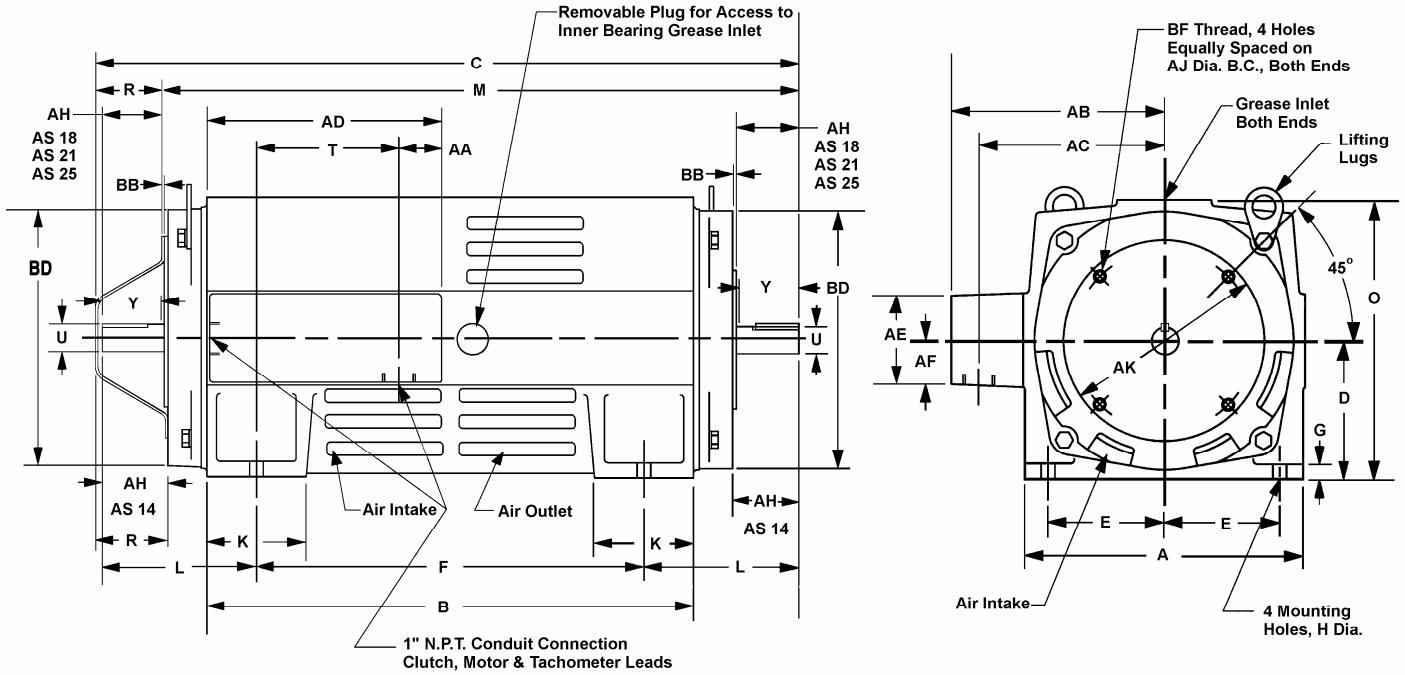

D-81255

AS	A	B	C	D ^①	E	F	G	H	K	L	M	O	R	T
14	9.00 229	15.72 399	22.72 577	4.50 114	3.75 95	12.52 318	.50 13	.50 13	3.20 81	5.00 127	20.38 518	9.06 230	2.34 59	4.67 119
18	10.50 267	17.60 447	27.90 709	5.25 133	4.25 108	13.75 349	.50 13	.50 13	3.75 95	6.25 159	23.60 599	10.75 273	4.05 103	4.43 113
21	12.50 318	18.60 472	30.27 769	6.25 159	5.00 127	14.12 359	.62 16	.62 16	3.56 90	7.62 194	26.22 666	12.62 321	4.05 103	5.58 142
25	14.00 356	17.75 451	32.84 834	7.00 178	5.50 140	15.06 383	.62 16	.62 16	3.30 84	8.75 222	28.79 731	14.38 365	4.05 103	6.20 157

AS	AA	AB	AC	AD	AE	AF	AH	AJ	AK ^②	BB	BD	BF	WT
14	1.32 34	7.06 179	6.00 152	7.50 190	2.88 73	1.48 38	2.12 54	5.88 149	4.499 114.3	.12 3	8.38 213	3/8-16 9.52 x 1.58	157 70
18	2.06 52	7.80 198	6.74 171	8.32 211	2.88 73	1.48 38	2.62 67	7.25 184	8.499 215.9	.25 6	10.06 255	1/2-13 12.70x1.95	277 112
21	1.38 35	8.87 225	7.57 192	8.81 224	3.76 96	1.92 49	3.12 79	7.25 184	8.499 215.9	.27 7	11.88 302	1/2-13 12.70x1.95	412 172
25	1.62 41	9.87 251	8.57 218	8.81 224	3.76 96	1.92 49	3.75 95	7.25 184	8.499 215.9	.27 7	13.32 338	1/2-13 12.7x1.95	610 240

AS	Shaft Extensions		
	U ^③	Y ^④	Key
14	.8750 22.225	1.94 49	.18 Sq. x 1.38 Lg. 4.76 Sq. x 35 Lg.
18	1.1250 28.575	2.50 64	.25 Sq. x 1.75 Lg. 6.35 Sq. x 44 Lg.
21	1.3750 34.925	3.00 76	.31 Sq. x 2.38 Lg. 7.87 Sq. x 60 Lg.
25	1.6250 41.275	3.62 92	.38 Sq. x 2.88 Lg. 9.65 Sq. x 73 Lg.

Overall dimension on units with modifications will be the total of M dimension plus R dimension. Unit may be operated vertically (prefer motor end output shaft up).

- ① D dimension will never be exceeded. When exact dimension is needed shims up to .03 inch (.76 mm) may be required.
- ② U shaft diameter tolerance 1.50 inches (38 mm) and smaller: +.0000/-.0005 inch (+.0000/-.0127 mm), over 1.50 inches (38mm): +.000/-0.001 inch (+.000/-0.25 mm).
- ③ Y dimension is maximum usable shaft length.
- ④ AK, pilot diameter tolerance +.000/-0.002 inch. (+.000/-0.051 mm). AJ, AK and KEY dimension are the same for both ends.

DIMENSIONS ARE IN INCHES AND MILLIMETERS

"AS" Ajusto-Spede® Drives 1 through 30 HP

Outline Drawings "C" Flange - AS-27

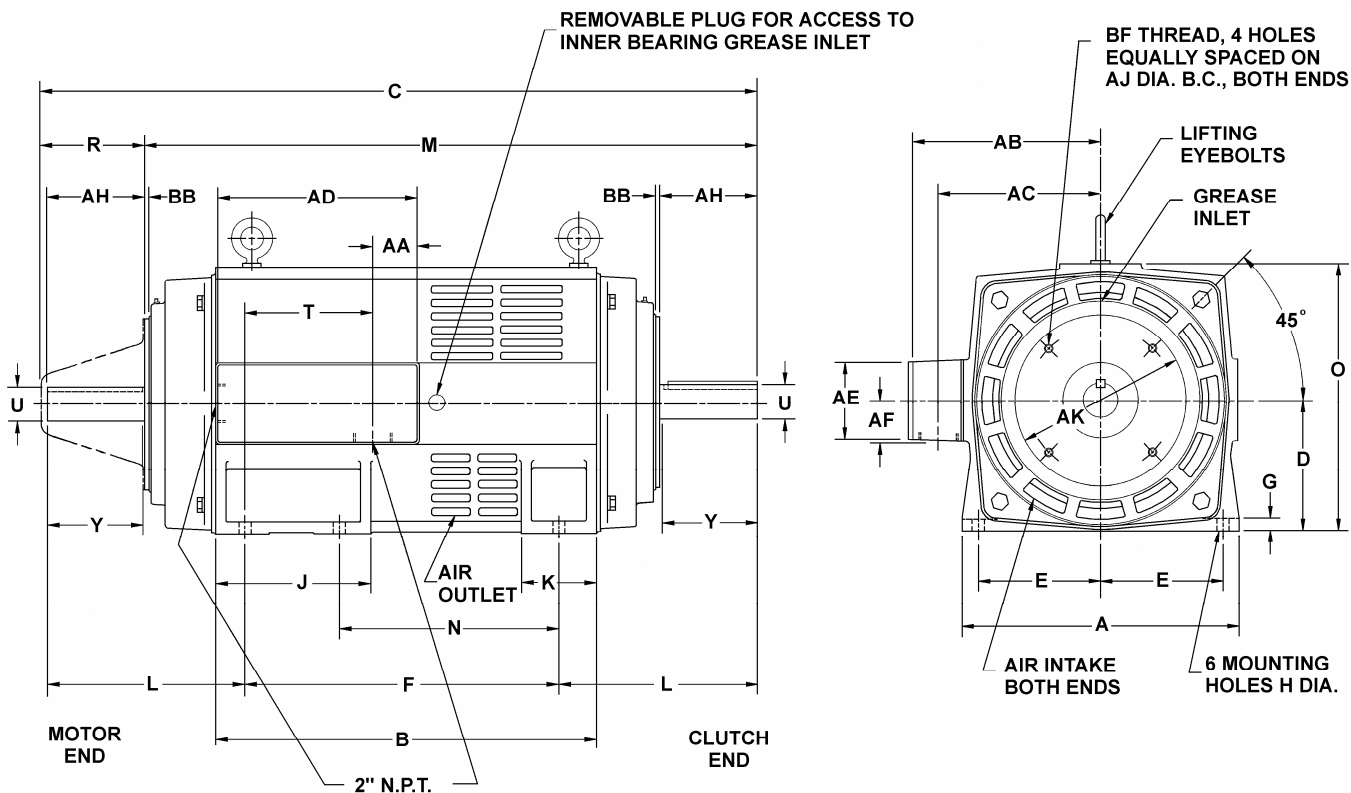

D-91127

AS	A	B	C	D ^①	E	F	G	H	J	K	L	M	N	O	R
27	17.00 432	23.38 594	39.60 1006	8.00 203	7.50 191	19.26 489	.75 19	.75 19	9.50 241	4.63 118	10.00 254	35.43 900	13.50 343	16.41 417	4.17 106
27 ^②	17.00 432	23.38 594	43.94 1116	8.00 203	7.50 191	19.26 489	.75 19	.75 19	9.50 241	4.63 118	12.17 309	37.60 995	13.50 343	16.41 417	6.34 161

AS	Shaft Extensions			AB	AC	AD	AE	AF	AH	AJ	AK ^③	BB	BF	WT
	U ^④	Y ^⑤	Key											
27	1.875 47.625	3.83 97	.50 Sq. x 3.50 Lg. 12.7 Sq. x 89 Lg.	12.73 323	10.72 272	12.25 311	4.75 121	2.46 62	3.83 97	9.00 228.6	10.499 266.67	.25 6	½ -13 12.7 x 1.95	1080 479
27 ^⑥	2.125 53.975	6.00 152	.50 Sq. x 5.50 Lg. 12.7 Sq. x 140 Lg.	12.73 323	10.72 272	12.25 311	4.75 121	2.46 62	6.00 152	9.00 228.6	10.499 266.67	.25 6	½ -13 12.7 x 1.95	1090 481

Overall dimension on units with modifications will be the total of **M** dimension plus **R** dimension. Unit may be operated vertically (prefer motor end output shaft up).

- ① **D** dimension will never be exceeded. When exact dimension is needed shims up to .03 inch (.76 mm) may be required.
- ② **U** Shaft diameter tolerance +.000/-.001 inch (+.000/-.025 mm).
- ③ **Y** dimension is maximum usable shaft length.
- ④ **AK**, pilot diameter tolerance +.000/-.002 inch (+.000/-.052 mm).
- AJ, AK** and **KEY** dimension are the same for both ends.
- ⑤ These dimensions with the large shaft diameter and length are standard only on Model AS-274004-01. All other AS-27 units will be supplied with the smaller shaft unless specifically ordered.
- All units below 40 HP will have 1.875 inch (47.625 mm) diameter shaft extension unless special ordered.
- All units 40 HP and above will have 2.125 inch (53.975 mm) diameter shaft extension unless special ordered.

DIMENSIONS ARE IN INCHES AND MILLIMETERS

"AS" Ajusto-Spede® Drives
1 through 30 HP

Modification Drawings - AS-14 through AS-27

ADJUSTABLE TORQUE BRAKE
(EDDY CURRENT BRAKE)

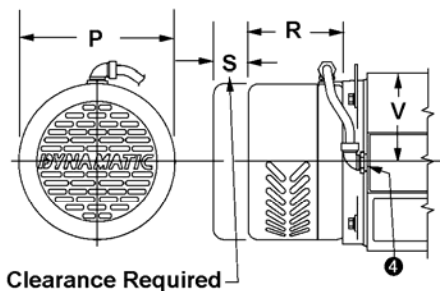

FRICTION BRAKE

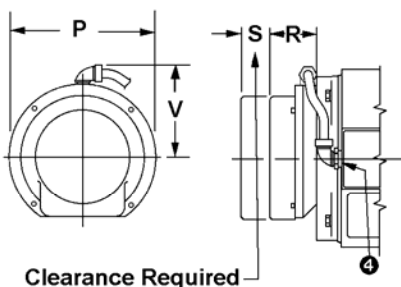

SPRING SET BRAKE
(FAIL-SAFE BRAKE)

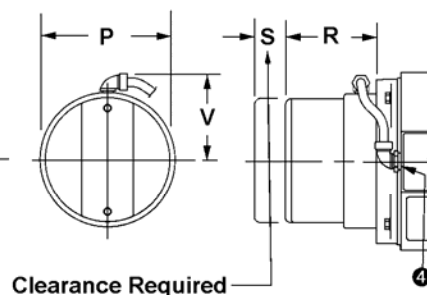

DRIP COVER FOR VERTICAL
OPERATION

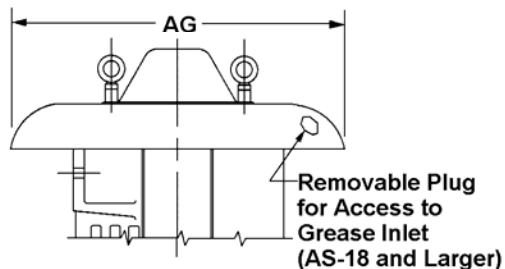

TEMPERATURE SWITCH

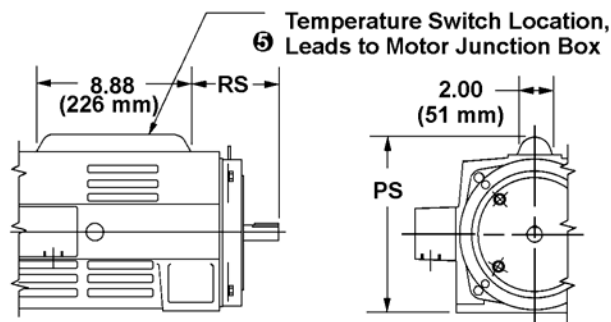

D-81255, D-91127

AS	Brakes												Vert.	Labyr. Seal	Temp. Switch			
	Adjustable Torque				Friction				Spring Set						AG	FY	PS	RS
	P	R	S	V	P	R	S	V	P	R	S	V						
14	7.38 187	4.69 119	2.92 74	5.19 132	7.42 188	2.46 62	1.10 .28	4.96 126	6.82 173	4.62 117	3.12 79	4.50 114	15.75 400	1.48 38	10.06 256	5.00 127		
18	9.50 241	5.84 148	4.56 116	6.19 157	7.42 188	3.11 79	1.10 .28	4.96 126	9.00 229	6.62 168	4.00 102	5.75 146	18.88 480	2.18 55	11.75 298	7.31 186		
21	9.50 241	5.84 148	4.56 116	6.19 157	11.52 293	4.45 113	2.68 68	6.00 152	9.00 229	6.62 168	4.00 102	5.75 146	18.88 480	2.68 68	13.62 346	8.77 223		
25	10.88 276	7.31 186	6.06 154	6.88 175	11.52 293	4.45 113	2.68 68	6.00 152	9.00 229	7.87 200	4.00 102	5.75 146	18.88 480	3.34 85	15.38 391	9.56 243		
27	15.68 398	5.81 148	1.50 38	9.12 232	12.16 309	4.72 120	2.25 57	6.08 155	11.00 279	8.50 216	4.00 102	6.75 171	22.00 559	3.39 86	17.38 441	11.03 280		
27 [Ⓞ]	15.68 398	8.00 203	3.67 93	9.12 232	12.16 309	-	-	-	11.00 279	-	-	6.75 171	22.00 559	5.56 141	17.38 441	13.20 335		

- Overall dimension with modifications will be the total of M dimension plus R dimension of the modification.
- S dimension is clearance to remove the cover.
- FY dimension is the maximum usable shaft length. Seal shortens the usable shaft length, Y.
- 1 N.P.T conduit connection for clutch, motor, brake and tachometer leads at bottom of junction box.
- Temperature switch: rated 120 to 600 VAC, 345 Volt Amperes, NC contacts, fixed temperature settings.
- See NOTE Ⓞ on AS-27 dimensions.

**"AS" Ajusto-Spede® Drives
1 through 30 HP**

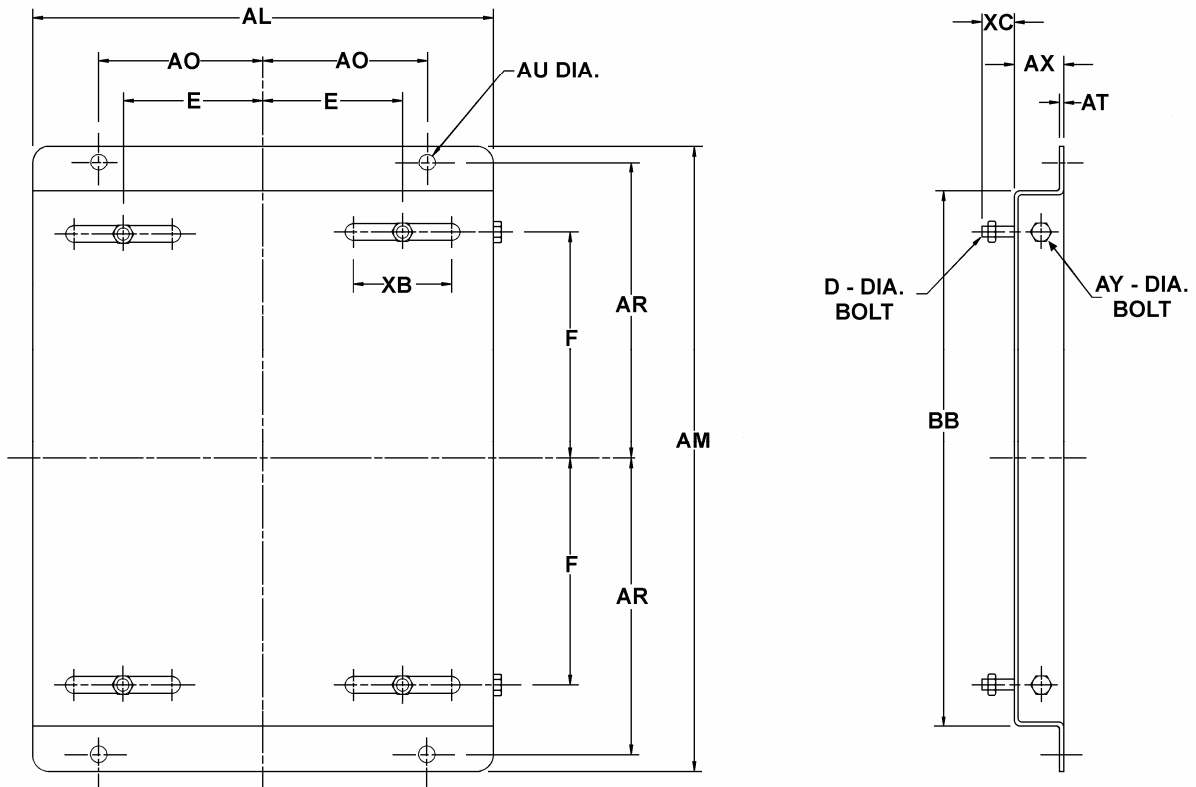

Outline Drawings - Adjustable Slide Bases

D-80907

AS	Part No.	AL	AM	AO	AR	AT	AU	AX	BB	E	F
14	80907-0100	12.75	18.00	4.50	8.50	.134	.50	1.50	15.00	3.75	6.26
18	80907-0200	14.00	19.00	5.00	9.00	.134	.50	1.50	16.25	4.25	6.87
21	80907-0300	16.00	20.50	6.00	9.50	.164	.50	1.75	17.12	5.00	7.06
25	80907-0400	18.00	22.75	7.00	10.38	.187	.62	2.00	18.62	5.50	7.53
27	80907-0500	22.00	27.50	9.00	12.75	.250	.75	2.25	23.50	7.50	9.63

AS	Part No.	XB	XC	D-Bolt	AY-Bolt
14	80907-0100	3.00	1.00	3/8 Dia.	1/2 Dia.
18	80907-0200	3.00	1.00	3/8 Dia.	1/2 Dia.
21	80907-0300	3.50	1.25	1/2 Dia.	1/2 Dia.
25	80907-0400	4.00	1.25	1/2 Dia.	5/8 Dia.
27	80907-0500	5.00	1.75	5/8 Dia.	5/8 Dia.

DIMENSIONS ARE IN INCHES